

16 x 2 Character LCD

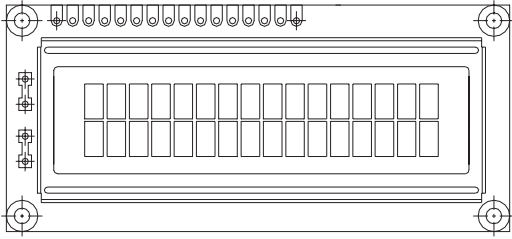

FEATURES

- 5 x 8 dots with cursor
- Built-in controller (KS 0066 or Equivalent)
- + 5V power supply (Also available for + 3V)
- 1/16 duty cycle
- B/L to be driven by pin 1, pin 2 or pin 15, pin 16 or A.K (LED)
- N.V. optional for + 3V power supply

MECHANICAL DATA

ITEM	STANDARD VALUE	UNIT
Module Dimension	80.0 x 36.0	mm
Viewing Area	66.0 x 16.0	mm
Dot Size	0.56 x 0.66	mm
Character Size	2.96 x 5.56	mm

ABSOLUTE MAXIMUM RATING

ITEM	SYMBOL	STANDARD VALUE			UNIT
		MIN.	TYP.	MAX.	
Power Supply	VDD-VSS	- 0.3	-	7.0	V
Input Voltage	VI	- 0.3	-	VDD	V

NOTE: VSS = 0 Volt, VDD = 5.0 Volt

ELECTRICAL SPECIFICATIONS

ITEM	SYMBOL	CONDITION	STANDARD VALUE			UNIT	
			MIN.	TYP.	MAX.		
Input Voltage	VDD	VDD = + 5V	4.7	5.0	5.3	V	
		VDD = + 3V	2.7	3.0	5.3	V	
Supply Current	IDD	VDD = 5V	-	1.2	3.0	mA	
Recommended LC Driving Voltage for Normal Temp. Version Module	VDD - V0	- 20 °C	-	-	-	V	
		0°C	4.2	4.8	5.1		
		25°C	3.8	4.2	4.6		
		50°C	3.6	4.0	4.4		
		70°C	-	-	-		
LED Forward Voltage	VF	25°C	-	4.2	4.6	V	
LED Forward Current	IF	25°C	Array	-	130	260	mA
			Edge	-	20	40	
EL Power Supply Current	IEL	Vel = 110VAC:400Hz	-	-	5.0	mA	

DISPLAY CHARACTER ADDRESS CODE:

Display Position	1	2	3	4	5	6	7	8	9	10	11	12	13	14	15	16
DD RAM Address	00	01														0F
DD RAM Address	40	41														4F

16 x 2 Character LCD

PIN NUMBER	SYMBOL	FUNCTION
1	Vss	GND
2	Vdd	+ 3V or + 5V
3	Vo	Contrast Adjustment
4	RS	H/L Register Select Signal
5	R/W	H/L Read/Write Signal
6	E	H →L Enable Signal
7	DB0	H/L Data Bus Line
8	DB1	H/L Data Bus Line
9	DB2	H/L Data Bus Line
10	DB3	H/L Data Bus Line
11	DB4	H/L Data Bus Line
12	DB5	H/L Data Bus Line
13	DB6	H/L Data Bus Line
14	DB7	H/L Data Bus Line
15	A/Vee	+ 4.2V for LED/Negative Voltage Output
16	K	Power Supply for B/L (OV)

DIMENSIONS in millimeters

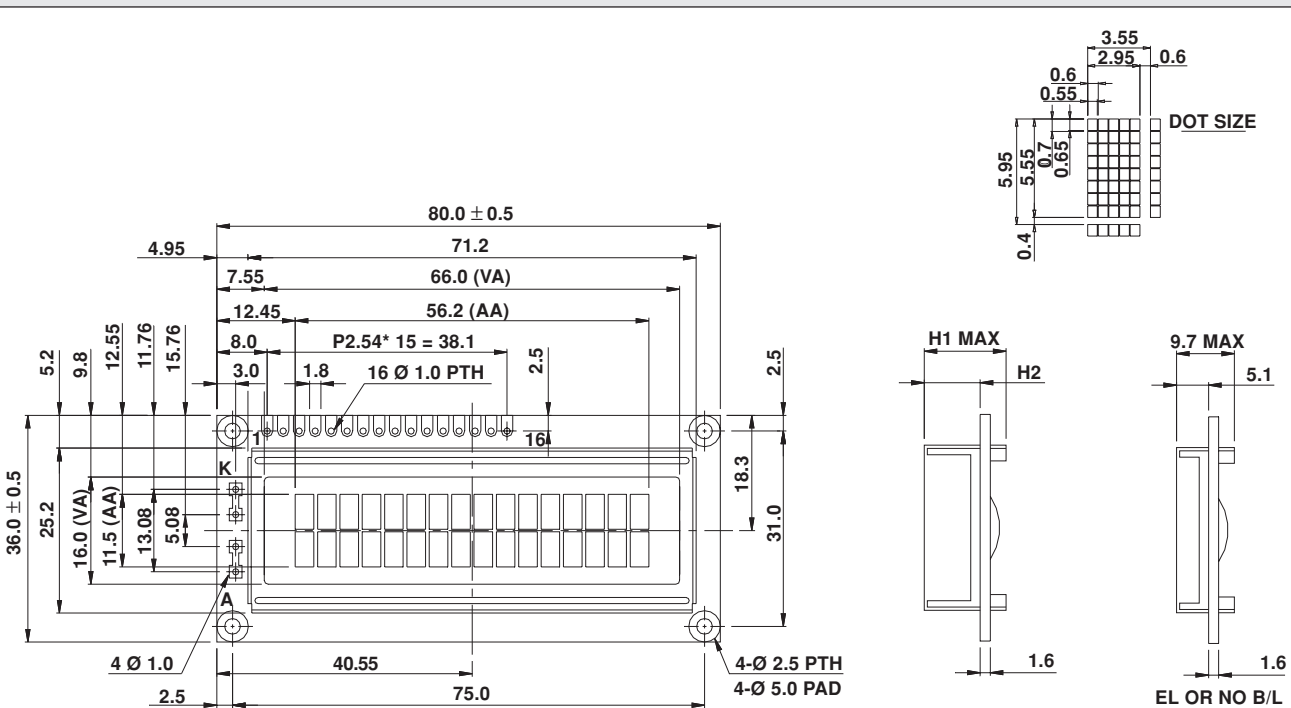

LED - H/L B/L		
	HIGH	LOW
H1	13.2	12.1
H2	8.6	7.5

