

# DMX Decoder for LED DMX Controllers 3 Channel

## User Manual



### Setup

Accepts DMX512 signal only when the DIP switch FUN=OFF, as Figure 1

DIP	1	2	3	4	5	6	7	8	9	10
Address	001	002	004	008	016	032	064	128	256	FUN

Specifications

DMX512 initial address code is equal to the total sum of the DIP switches numbered from 1 to 9, Placing the DIP switch in the DOWN position sets it's value to ON. Placing the DIP switch in the UP position sets it's value to OFF.

**For example: Set initial address to 37.**

As figure 2, set the 6th, 3rd and 1st bit of the DIP switch downward to "1", the rest to "0", the total sum from 1 to 9 is  $32+4+1$ , so the DMX512 initial address code is 37.

When FUN=OFF, Decoder is DMX controlling mode  
 When FUN=ON, Decoder is in self-test mode.

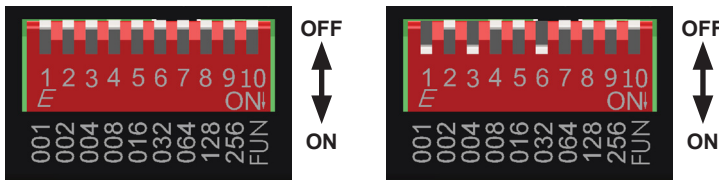

Figure 1



Figure 2

**Example 2: set initial address to 328.**

Set the 4th, 7th, 9th, bit of the DIP switch downward to "1" the rest to "0" (as Figure 3). the summation from 1 to 9 is  $8+64+256$ , so the DMX512 original address code is 328.



Figure 3

### Testing Function.

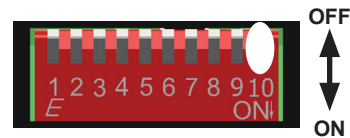

As figure, FUN=ON: test function: 1-9DIP switch =OFF: BLACK

DIP 1	DIP 2	DIP 3	DIP 4	DIP 5	DIP 6	DIP 7	DIP 8	DIP 9
Red	Green	Blue	Yellow	Purple	Cyan	White	Jump	Gradual

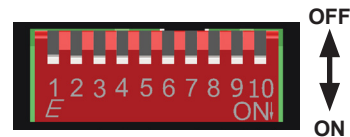

1-7 is to set 8 speed levels.  
 7 is the fastest level, while dip switch 1-7=OFF: the speed is 0.

DIP 1	DIP 2	DIP 3	DIP 4	DIP 5	DIP 6	DIP 7
Speed 1	Speed 2	Speed 3	Speed 4	Speed 5	Speed 6	Speed 7

As figure, the color changing mode is selected with a speed level of 7 when all the dip switches=ON.

## Connection Diagram for DMX signal

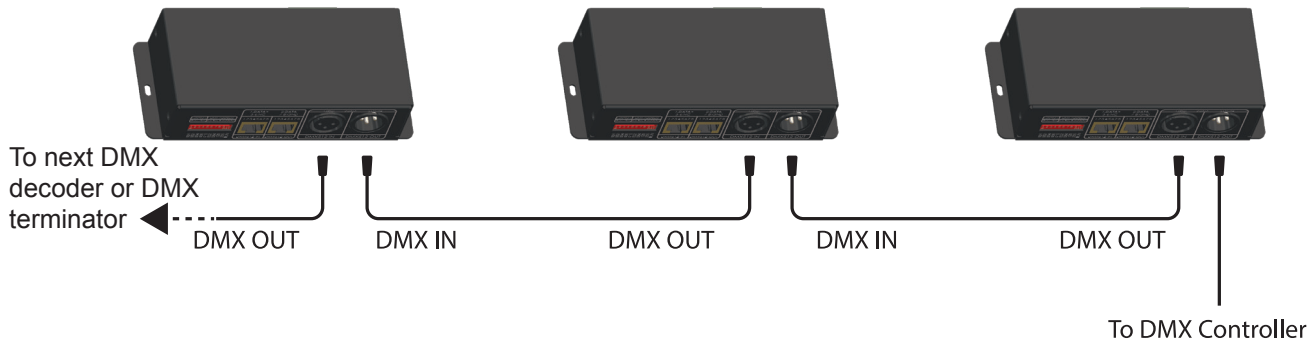

## Connection Diagram for LED Lights

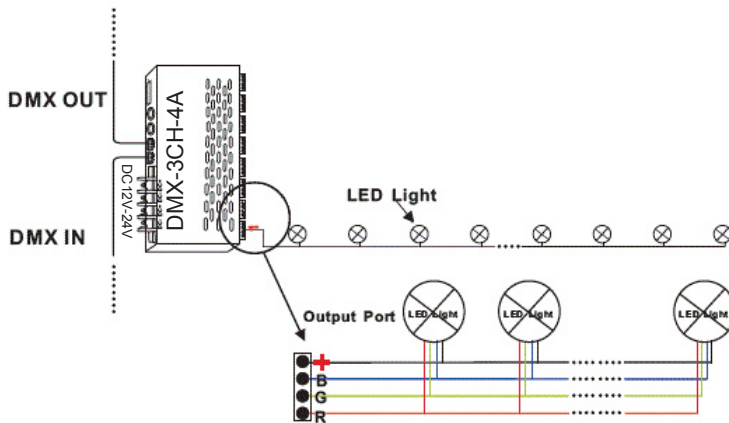

## Warranty Agreement

1. A Lifetime Warranty is given from the date of purchase. The warranty is for free repair or replacement and covers manufacturing faults only.
2. Warranty exclusions:
  - Any man-made damages caused from improper operation, or connecting to excess voltage and overloading.
  - The product appears to have excessive physical damage.
  - Damage due to natural disasters and accidents.
3. Repair or replacement as provided under this warranty is the exclusive remedy to the customer. We shall not be liable for any incidental or consequential damages for breach of any stipulation in this warranty.
4. Lifetime warranty is valid for the original purchaser only and is not transferable.

## Attention

1. The product shall be installed and serviced by a qualified person.
2. This product is non-waterproof. Avoid the sun and rain. When installed outdoors please ensure it is mounted in a waterproof enclosure.
3. Good heat dissipation will prolong the working life of the controller. Ensure good ventilation.
4. Check if the output voltage of any LED power supplies used comply with the working voltage of the product.
5. Ensure that adequate sized cable is used from the controller to the LED lights to carry the current. Also ensure that the cable is secured tightly in the connector to avoid the accidents due to overheating and poor contact on the wire.
6. Ensure all wire connections and polarities are correct before applying power to avoid any damages to the LED lights.
7. If a fault occurs return the product to your supplier. Do not attempt to fix the product by yourself.