

## Pin Descriptions: RFM31B

### RFM31B-S1

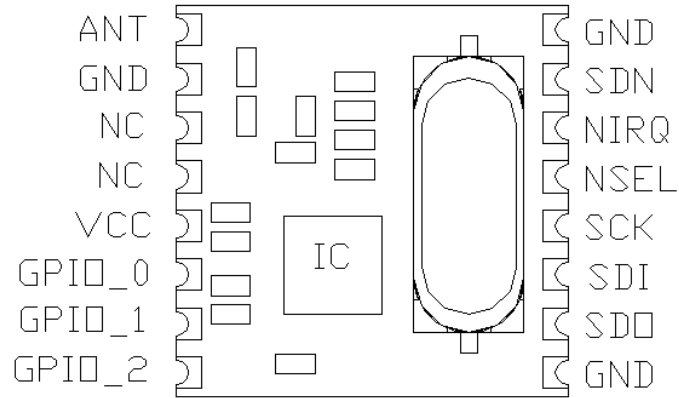

### RFM31B-S2

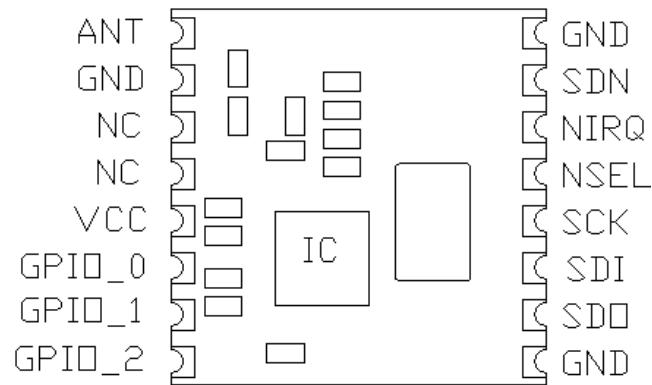

### RFM31B-D

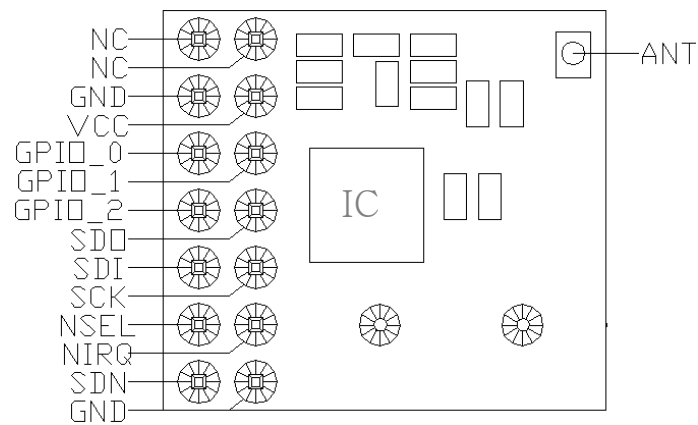

# RFM31B

---

VCC	S	+1.8 to +3.6 V supply voltage. The recommended Vcc supply voltage is +3.3 V.
GND	S	Ground reference.
GPIO_0	I/O	General Purpose Digital I/O that may be configured through the registers to perform various functions including: Microcontroller Clock Output, FIFO status, POR, Wake-Up timer, Low Battery Detect, TRSW, AntDiversity control, etc. See the SPI GPIO Configuration Registers, Address 0Bh, 0Ch, and 0Dh for more information.
GPIO_1	I/O	
GPIO_2	I/O	
SDO	O	0–Vcc V digital output that provides a serial readback function of the internal control registers.
SDI	I	Serial Data input. 0–Vcc V digital input. This pin provides the serial data stream for the 4-line serial data bus.
SCLK	I	Serial Clock input. 0–VDD V digital input. This pin provides the serial data clock function for the 4-line serial data bus. Data is clocked into the RFM31 on positive edge transitions.
nSEL	I	Serial Interface Select input. 0– Vcc V digital input. This pin provides the Select/Enable function for the 4-line serial data bus. The signal is also used to signify burst read/write mode.
nIRQ	O	General Microcontroller Interrupt Status output. When the RFM31 exhibits anyone of the Interrupt Events the nIRQ pin will be set low=0. Please see the Control Logic registers section for more information on the Interrupt Events. The Microcontroller can then determine the state of the interrupt by reading a corresponding SPI Interrupt Status Registers, Address 03h and 04h.
SDN	I	Shutdown input pin. 0–Vcc V digital input. SDN should be = 0 in all modes except Shutdown mode. When SDN =1 the chip will be completely shutdown and the contents of the registers will be lost.
ANT	I/O	RF signal input.(50 OHM input Impedance)
NC		No Connection