

LCD DISPLAY 20X4

User Manual

1. Basic Specifications

1.1 Display Specifications

- 1) LCD Display Mode : STN, Positive, Transflective
- 2) Display Color : Display Data = "1" : Deep Blue (*1)
: Display Data = "0" : Light Gray(*2)
- 3) Viewing Angle : 6H
- 4) Driving Method : 1/16 duty, 1/5 bias
- 5) Back Light : Yellow-Green LED backlight

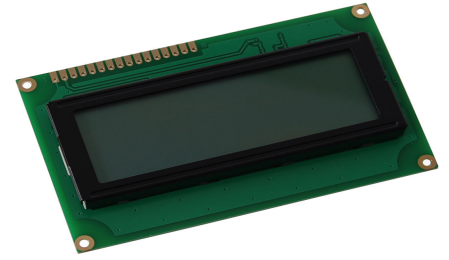

Note:

- *1. Color tone may slightly change by Temperature and Driving Condition.
- *2. The Color is defined as the inactive / background color

1.2 Mechanical Specifications

- 1) Outline Dimension : 100.0 x 60.0 x 13.7MAX
(See attached Outline Drawing for details)

1.3 Block Diagram

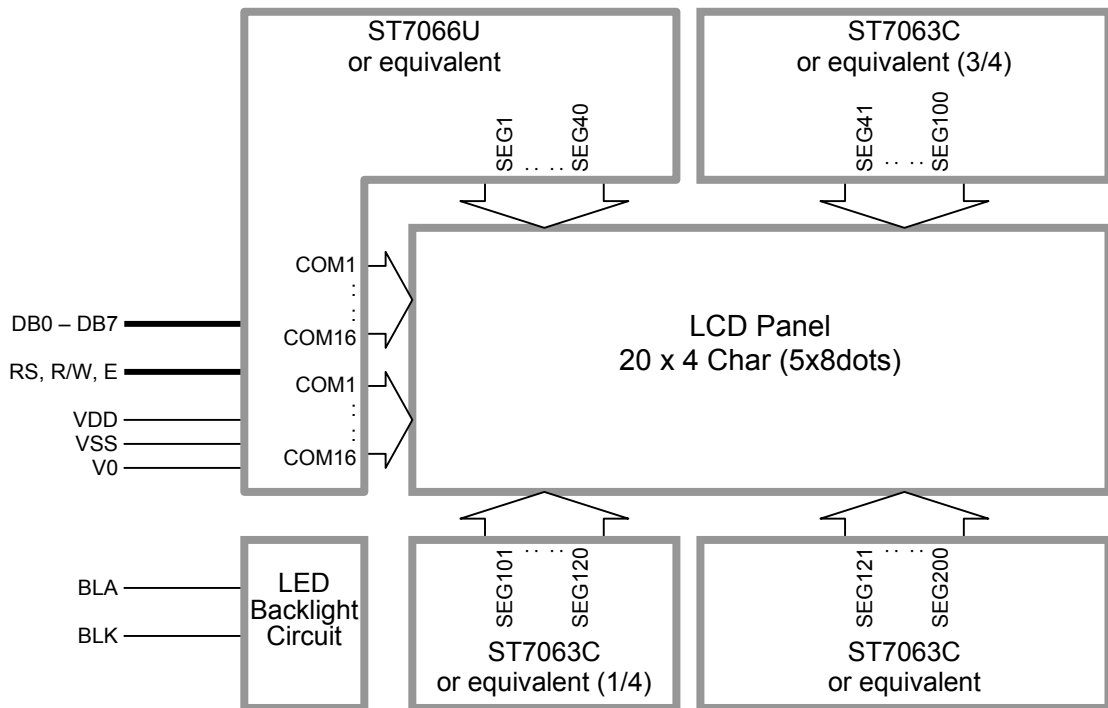

1.4 Terminal Functions

Pin No.	Pin Name	I/O	Descriptions
1	VSS	Power	Power supply, Ground (0V)
2	VDD	Power	Positive power supply
3	V0	Power	LCD contrast reference supply
4	RS	Input	Register Select RS=HIGH: transferring display data RS=LOW: transferring instruction data
5	R/W	Input	Read / Write Control: R/W=HIGH: Read mode selected R/W=LOW: Write mode selected
6	E	Input	Data Enable
7	DB0	I/O	Bi-directional tri-state Data bus In 8 bit mode, DB0 ~ DB7 are in use In 4 bit mode, DB4 ~ DB7 are in use, DB0~DB3 leave open
:	:		
14	DB7		
15	BLA	Power	Backlight positive supply
16	BLK	Power	Backlight negative supply



Electronics Katiangi Trading

2. Absolute Maximum Ratings

Items	Symbol	Min.	Max.	Unit	Condition
Supply Voltage	V_{DD}	0	6.0	V	$V_{SS} = 0V$
Input Voltage	V_{IN}	0	V_{DD}	V	$V_{SS} = 0V$
Operating Temperature	T_{OP}	-20	70	°C	No Condensation
Storage Temperature	T_{ST}	-30	80	°C	No Condensation

Cautions:

Any Stresses exceeding the Absolute Maximum Ratings may cause substantial damage to the device. Functional operation of this device at other conditions beyond those listed in the specification is not implied and prolonged exposure to extreme conditions may affect device reliability.

3. Electrical Characteristics

3.1 DC Characteristics

$V_{SS}=0V, V_{DD}=5.0V, T_{OP}=25^{\circ}C$

Items	Symbol	MIN.	TYP.	MAX.	Unit	Condition / Application Pin
Operating Voltage	V_{DD}	4.7	5.0	5.3	V	VDD
Input High Voltage	V_{IH}	$0.8 \times V_{DD}$	-	V_{DD}	V	RS, R/W, E, DB0 ~ DB7
Input Low Voltage	V_{IL}	V_{SS}	-	0.5	V	
Output High Voltage	V_{OH}	$0.7 \times V_{DD}$	-	V_{DD}	V	$I_{OH}=-0.1mA, DB0 \sim DB7$
Output Low Voltage	V_{OL}	V_{SS}	-	0.5	V	$I_{OL}=0.1mA, DB0 \sim DB7$
Operating Current	I_{DD}	-	1.5	3.5	mA	VDD, VSS

3.2 LED Backlight Circuit Characteristics

$V_{BLK}=0V, I_{f_{BLA}}=180mA, T_{OP}=25^{\circ}C$

Items	Symbol	MIN.	TYP.	MAX.	Unit	Applicable Pin
Forward Voltage	$V_{f_{BLA}}$	-	5.0	-	V	BLA
Forward Current	$I_{f_{BLA}}$	-	-	260	mA	BLA

Cautions:

Exceeding the recommended driving current could cause substantial damage to the backlight and shorten its lifetime.

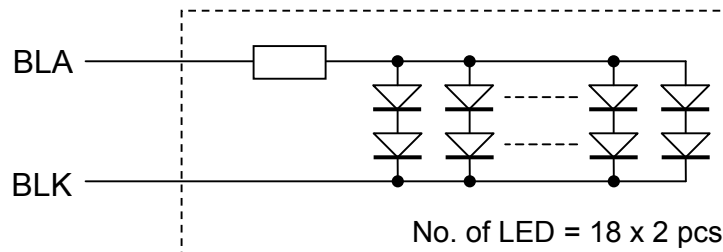

3.3 AC Characteristics

$V_{SS}=0V, V_{DD}=5V, T_{OP}=25^{\circ}C$

Item	Symbol	MIN.	TYP.	MAX.	Unit
E cycle time	t_c	1500	-	-	ns
E high level width	tpw	175	-	-	ns
E rise time	t_r	-	-	20	ns
E fall time	t_f	-	-	20	ns
Address set-up time	t_{as}	5	-	-	ns
Address hold time	t_{ah}	13	-	-	ns
Data set-up time	t_{dsw}	50	-	-	ns
Data delay time	t_{ddr}	-	-	125	ns
Data hold time	t_h	13	-	-	ns

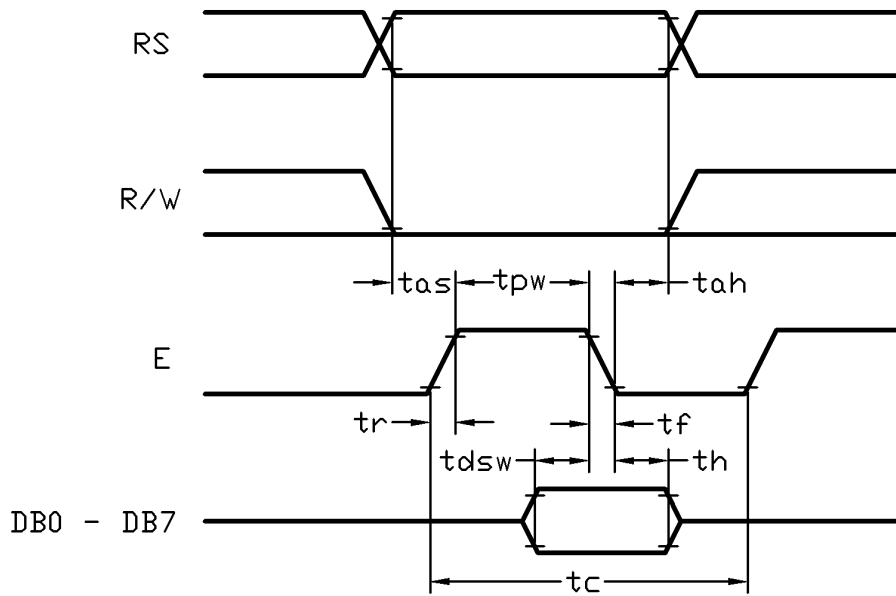

Host Write Timing Diagram

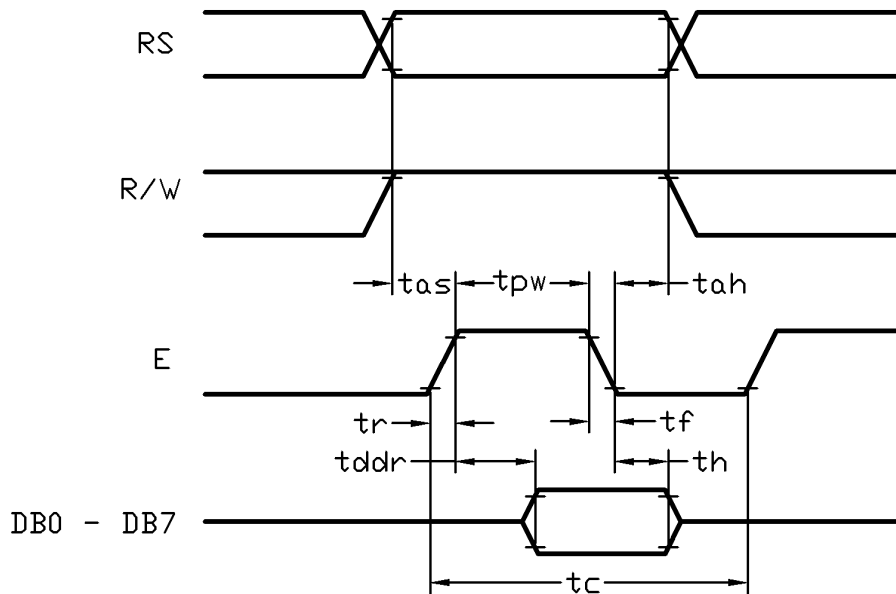

Host Read Timing Diagram

4. Function Specifications

4.1 Basic Setting

To drive the LCD module correctly and provide normally display, please use the following setting

- N=1, 2-line display
- F=0, 5x8 dots font
- D=1, display on

Note:

*1. These setting/commands should issue to the LCD module while start up.

*2. See the Display Commands section for details.

4.2 Resetting the LCD module

When turning on the VDD and VSS power supply, LCD module will execute the reset routine automatically. It takes about 80ms. After the reset routine, the LCD module status will be as follow:

- Display clear
- DL=1, 8-bit interface
- N=0, 1-line display
- F=0, 5x8 dot character font
- D=0, Display off
- C=0, Cursor off
- B=0, Blinking off
- I/D=1, Increment by 1
- S=0, No shift

Note:

*1. Reset routine could not generate the Basic Setting

4.3 Adjusting the LCD display contrast

A Variable-Resistor must be connected to the LCD module for providing a reference supply to V0. Adjusting the VR will result the change of LCD display contrast. The recommended value of VR is 5k Ohm.

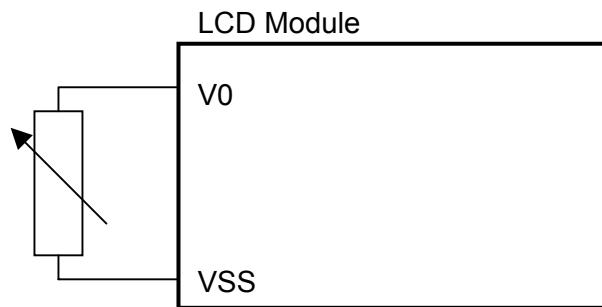

4.4 Display Memory Map

There are two main memory-areas in the LCD module for display.

- Character Generator RAM (CGRAM)
- Display Data RAM (DDRAM)

4.4.1 Character Generator RAM (CGRAM)

Character Generator RAM is for storing the User-defined Characters (5x8 dots font). Totally 8 User-defined Characters (character code = 00h ~ 07h) could be created.

The User-defined Character Codes are 00h and 07h. They could be called into DDRAM as normal character.

User-defined Character Code	CGRAM Address	CGRAM Data (Font Pattern)	
		D7 ~ D5	D4 ~ D0
00h (08h)	00h 01h ⋮ 06h 07h	Not Use	5 x 8 dots font pattern
01h (09h)	08h 09h ⋮ 0Eh 0Fh		
02h (0Ah)	10h 11h ⋮ 16h 17h	Not Use	5 x 8 dots font pattern
03h (0Bh)	18h 19h ⋮ 1Eh 1Fh		
04h (0Ch)	20h 21h ⋮ 26h 27h	Not Use	5 x 8 dots font pattern
05h (0Dh)	28h 29h ⋮ 2Eh 2Fh		
06h (0Eh)	30h 31h ⋮ 36h 37h	Not Use	5 x 8 dots font pattern
07h (0Fh)	38h 39h ⋮ 3Eh 3Fh		

CGRAM Address Map

4.4.2 Display Data RAM (DDRAM)

ROM Characters (Character Code = 10h ~ FFh) could be written into DDRAM for displaying the Character (5x8 dots font). User-defined Characters (Character Code = 00h ~ 07h) stored in CGRAM could also be use. Calling Character Code 08h ~ 0Fh will call out User-defined Characters 00h ~ 07h respectively.

		COLUMN											
		1 st	2 nd	3 rd	4 th	5 th	⋮	16 th	17 th	18 th	19 th	20 th	
ROW	1 st	00h	01h	02h	03h	04h	⋮	0Fh	10h	11h	12h	13h	
	2 nd	40h	41h	42h	43h	44h	20 x 4 Characters (5x8 dots font)	4Fh	50h	51h	52h	53h	
	3 rd	14h	15h	16h	17h	18h		23h	24h	25h	26h	27h	
	4 th	54h	55h	56h	57h	58h	⋮	63h	64h	65h	66h	67h	

DDRAM Address Map

Note:

- *1. The mapping is based on top view of the LCD module
- *2. N=1, 2-line display
- *3. F=0, 5x8 dots font
- *4. D=1, display on

4.5 Character Code Rom

Please refer to ST7066U-0A Data sheet



Display Commands

No.	Instructions	Code										Function	
		RS	R/W	DB7	DB6	DB5	DB4	DB3	DB2	DB1	DB0		
1	Clear Display	0	0	0	0	0	0	0	0	0	1	Write "20h" to DDRAM and set DDRAM address (AC) to "00h"	
2	Return Home	0	0	0	0	0	0	0	0	0	1	x	Set DDRAM address (AC) to "00h" and return cursor to its original position if shifted (DDRAM contents are not change)
3	Entry Mode Set	0	0	0	0	0	0	0	0	1	I/D	S	Set cursor moving direction and specify display shift, during data read and write of DDRAM and CGRAM. S=1, screen shifting; S=0, no screen shifting I/D=1, AC=AC+1 and if S=1, screen shift left I/D=0, AC=AC-1 and if S=0, screen shift right
4	Display ON/OFF	0	0	0	0	0	0	0	1	D	C	B	D=1, display on; D=0, display off C=1, cursor on; C=0, cursor off B=1, cursor blinking on; B=0, cursor blinking off
5	Cursor or Display Shift	0	0	0	0	0	0	1	S/C	R/L	x	x	Move the cursor or shift the display, where DDRAM contents. S/C=1, shift screen; S/C=0, shift cursor R/L=1, to right-side; R/L=0, to left side (if S/C=1, AC will not be changed)
6	Function Set	0	0	0	0	0	1	DL	N	F	x	x	DL=1, 8-bit interface; DL=0, 4-bit interface N=1, 2-line display; N=0, 1-line display F=1, 5x11 dots font; F=0, 5x8 dots font
7	Set CGRAM address	0	0	0	1	AC5	AC4	AC3	AC2	AC1	AC0		Set CGRAM address in address counter
8	Set DDRAM address	0	0	1	AC6	AC5	AC4	AC3	AC2	AC1	AC0		Set DDRAM address in address counter
9	Read Busy flag & address	0	1	BF	AC6	AC5	AC4	AC3	AC2	AC1	AC0		Check the system status and get the address counter content (AC6~AC0). BF=1, busy; BF=0, ready
10	Write data to RAM	1	0	D7	D6	D5	D4	D3	D2	D1	D0		Write the data into internal RAM, where the address counter pointing at.
11	Read data from RAM	1	1	D7	D6	D5	D4	D3	D2	D1	D0		Read the data from internal RAM, where the address counter pointing at.

Note:

*1. Do not use any other command not listed, or the system malfunction may result.

*2. For the details of the Display Commands, please refer to S6A0069 datasheet.

5. Design and Handling Precaution

1. The LCD panel is made by glass. Any mechanical shock (eg. dropping from high place) will damage the LCD module.
2. Do not add excessive force on the surface of the display, which may cause the Display color change abnormally.
3. The polarizer on the LCD is easily get scratched. If possible, do not remove the LCD protective film until the last step of installation.
4. Never attempt to disassemble or rework the LCD module.
5. Only Clean the LCD with Isopropyl Alcohol or Ethyl Alcohol. Other solvents (eg. water) may damage the LCD.
6. When mounting the LCD module, make sure that it is free from twisting, warping and distortion.
7. Ensure to provide enough space (with cushion) between case and LCD panel to prevent external force adding on it, or it may cause damage to the LCD or degrade the display result.
8. Only hold the LCD module by its side. Never hold LCD module by add force on the heat seal or TAB.
9. Never add force to component of the LCD module. It may cause invisible damage or degrade of the reliability.
10. LCD module could be easily damaged by static electricity. Be careful to maintain an optimum anti-static work environment to protect the LCD module.
11. When peeling off the protective film from LCD, static charge may cause abnormal display pattern. It is normal and will resume to normal in a short while.
12. Take care and prevent get hurt by the LCD panel sharp edge.
13. Never operate the LCD module exceed the absolute maximum ratings.
14. Keep the signal line as short as possible to prevent noisy signal applying to LCD module.
15. Never apply signal to the LCD module without power supply.
16. IC chip (eg. TAB or COG) is sensitive to the light. Strong lighting environment could possibly cause malfunction. Light sealing structure casing is recommend.
17. LCD module reliability may be reduced by temperature shock.
18. When storing the LCD module, avoid exposure to the direct sunlight, high humidity, high temperature or low temperature. They may damage or degrade the LCD module