

Radio AM/FM Kit

Model:ZX 2051



Introduction:

This kit is an IC FM & AM radio featuring high sensitivity, stable quality, clear and loud voice and low power consumption for electronic experiments ideally.

Rationale:

1. The medium wave signal inputs through a circuit insisting of T1 and C-1. After selected, it enters the tenth pin inside IC and mixed with local oscillating sign composed of T2, C-2 and the oscillator within the fifth IC pin. The differential frequency signal inputs through the fourteenth IC pin after mixed, enters in the IC for medium frequency amplification and detection from the sixteenth pin after selected through medium-frequency transformer T3 and ceramic filter CF2, and then inputs through the 23rd pin, couples to the 24th pin through C14 to amplify and finally inputs to speaker through the 27th pin.

2. The FM signal received by TX into the IC 12th pin through C2 HF amplifier and mixer, passes through 9-pin externally connected to C-3, LI frequency selection circuit, 7 pin externally connected to C-4 and L2 local oscillator circuit. The mixed IF signal inputs through the fourteenth pin, enters in the seventeenth pin for IF amplification after frequency-selection by 10.7MHz ceramic filter CF1 and subjects to the internal frequency discriminator by the second IC pin that externally links to frequency discriminator network. The audio signal after through the discriminator inputs through the 23rd pin, couples by C14 to the 24th pin for amplification and finally inputs by the 27th pin to allow the speaker voicing. 3. The quadruple variable capacitor C consists of 4 separate variable capacitors rotating on an axis to address AM and FM. Care should be paid to two capacitors of smaller capacitance welded to Pin 7 and 9(for FM only) and two capacitors of large capacitance welded to Pin 5 and 10(for AM only). CF2 is an AM IF ceramic filter while CF1 is an FM IF ceramic filter, T2 a medium-wave oscillator coil, F3 a frequency discriminator, T3 an AM IF transformer, LI an FM input inductor in 4.5 coils and L2 an FM oscillator in 5.5 coils.

Introduction to Assembly:

1. Please check the kits according to List of Parts, measure the parts by using a multimeter, in particular measure the ceramic chip capacitance by using the digital multimeter. Be conscious of the parameters roughly determined with multimeter if necessary.
2. Please weld the smaller parts, then bigger ones and finally the integrated circuit. It is better to mount the parts close to the substrate appropriately. Do not insert the elements by mistakes. Please weld the IC CD 1691 chip from Japan's Sony Corp. is dual-row 28-pin that is intensively arranged. Once failed, weld them after they are cooled down to avoid IC scorching. Please inspect if there are welding defects such as dry, poor and error joints residual times and circuit short

accidents. Once successfully assembled according to above requirements, you can receive the AM broadcast after fitting the batteries and FM broadcast after welding the antenna. If failed to receive the broadcast, it is conducive to recheck if there are mistakes in the circuit and refer to Tables inclusive of IC pin reference voltages (static)) in this Instruction (Note that CD1019 can a direct alternative to CXA1691BM).

3. IF (AM) adjustment: it is ready to adjust justly setting the radio stations at the medium wave bands because all parameters are designed on the IC.
4. FM adjustment (welding the antenna and set K2 at FM side before adjustment): LI and L2 are separately used to adjust the frequencies in the HF amplifier (combining the fine-tuning of C-3 top) and oscillator (combining the fine-tuning of C—4 top). When adjusting the LI and L2, loose with non-inductive screwdriver whilst it is critical to adjust the L2 which affecting the coverage and performance of radio station. The T2 and T3 have been adjusted to the specified frequencies at shipment and just require tuning to left or right a little.

List of Parts:

SN	Name	Model	Pos. No.	Qty.
1	IC	CD1691CB	IC	1
2	Light-emitting diodes	Φ 3 red	LED	1
3	Magnetic rod and coil	5x13x55	T1	1
4	Oscillator coil	Red IF transformer	T2	1
5	IF transformer	Black IF	T3	1
6	Filter	10.7M 3-pin	CF1	1
7	Filter	455KHz	CF2	1
8	Frequency discriminator	10.7M 2-pin	CF3	1
9	Hollow inductor	Φ 3 x 4.5T	L2	1
10	Hollow inductor	Φ 3 x 5.5T	LI	1
11	Speaker	0.25W 4-16Ω	BL	1
12	Potentiometer	50K Ω	RP	1
13	Resistor	100 Ω	R4	1
14	Resistor	150 Ω	R2	1
15	Resistor	330 Ω	R5	1
16	Resistor	2K Ω	R3	1
17	Resistor	100K Ω	R1	1
18	Ceramic capacitors	1P	C5	1
19	Ceramic capacitors	15P	C3,C4	2
20	Ceramic capacitors	30P	C1,C2	2
21	Ceramic capacitors	121	C16	1
22	Ceramic capacitors	221	C11	1
23	Ceramic capacitors	103	C9,10,22	3
24	Ceramic capacitors	223	C15	1
25	Ceramic capacitors	104	C7,14,18,20	4

SN	Name	Model	Pos. No.	Qty.
26	Electrolytic capacitor	10 μ F	C8,12,13,17	4
27	Electrolytic capacitor	220 μ F	C19,21	2
28	Electrolytic capacitor	4.7 μ F	C6	1
29	Quadruple capacitor	CBM-443PF	C(1,2	1
30	Band switch		C(1,2,3,4)	1
31	Headphone jack	Φ 3.5mm	K2	1
32	Lug plate	Φ 3.2mm	CK	1
33	Scale panel			1
34	Tuning dial			1
35	Potentiometer dial			1
36	Rod bracket			1
37	PCB			1
38	Assembly Instruction			1
39	Battery poles	3		1
40	Wire	Red, black and		5
41	Upper cover			1
42	Lower cover			1
43	Screws	Φ 2.5x5		4
44	Screws	Φ 1.6 x 4		1
45	Self-tapping screws	Φ 3 x 6		2
46	Rod antenna			1
47	Pointer paper			1
48	Speaker plate			2
49	Switch knob			1
50	Self-tapping screw	Φ 2x5		1

Circuit Diagram:

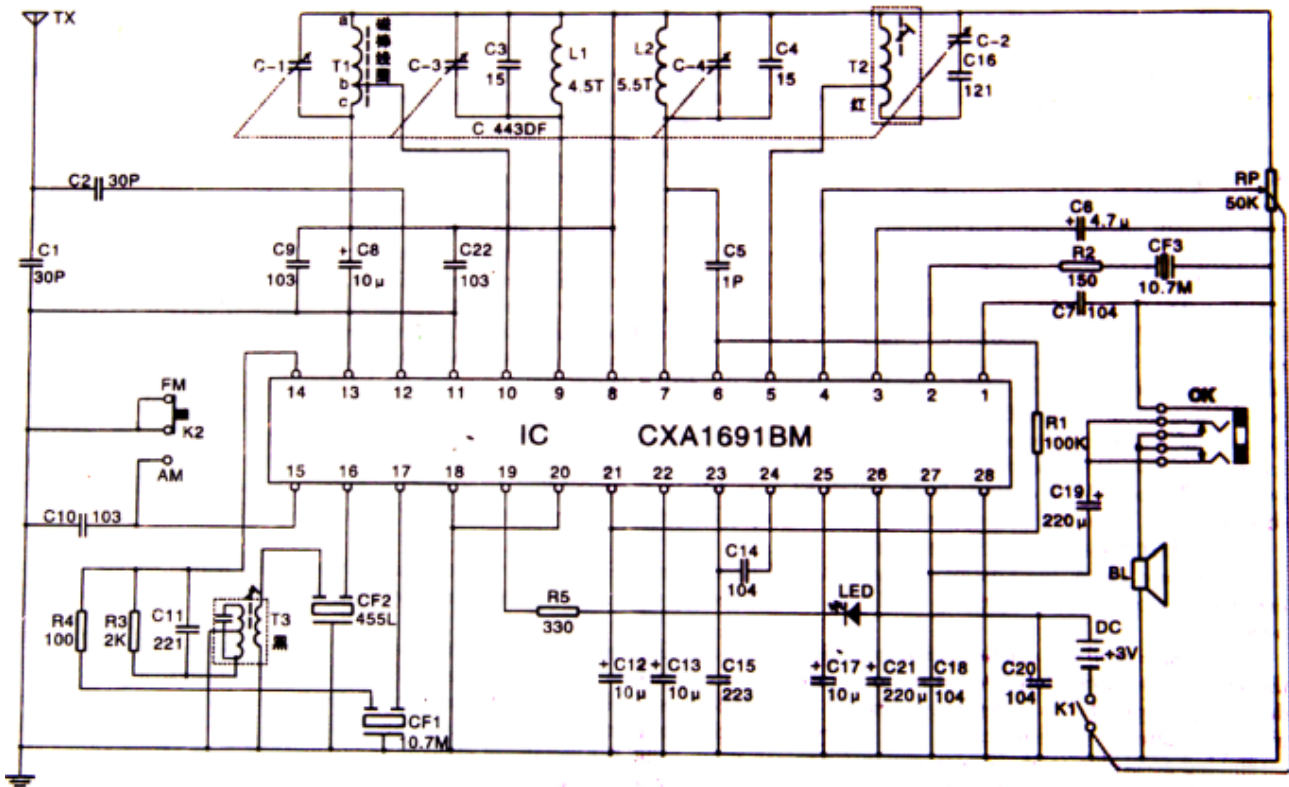

PCB and Others:

Color Ring Resistance Color Number

0	1	2	3	4	5	6	7	8	9
B	Br.	R	O	Y	G	B	P	Gr.	W

9013
9014
9018
3DG201



Plins of triodes

Magnetic Rod Coil



Resistance Calculation

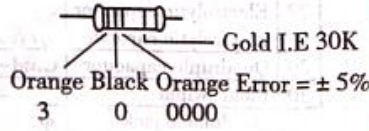

Ceramic Capacitor

Symbol: Instance: The first and second digits stand for capacitance The third digit for number of 0, i.e. 22000P=0.022 μ f

Electrolytic Capacitor

